

**859D
DUAL CHAIN
BLENDING HOPPER**

1st Edition

CAT070



Owner's Name _____

Dealer's Name _____

Serial Number _____

Date Purchased _____

TABLE OF CONTENTS

CAT070
1st Edition
September 15, 1991

859D DUAL CHAIN BLENDING HOPPER

SECTION	PAGE
1. Panels & Shields Section.....	3
2. Boards Section.....	5
3. Drive Section.....	7
4. Variable Speed Gearbox Drive Section - Optional.....	9
5. Inverter Drive Section - Optional.....	11
6. Polyethylene Slide Kit Section - Optional.....	13
7. Decals Section.....	15
Numerical Parts Index.....	16
Warranty	

NOTE

The terms "Left" and "Right" used in the description of parts are determined by facing the direction of the flow of material through the machine.

Owners Name _____

Address _____

Model No. _____ Serial No. _____ Date Purchased _____

1100 Holland Road Suffolk, VA 23434 U.S.A. (804) 539-0231
Telex - 494-6083 / Fax - (804) 934-3264

1701 S. Slappey Blvd./P.O. Box 3687 Albany, GA 31706
(912) 439-2217 / Fax (912) 439-9343

A M A D A S
INDUSTRIES

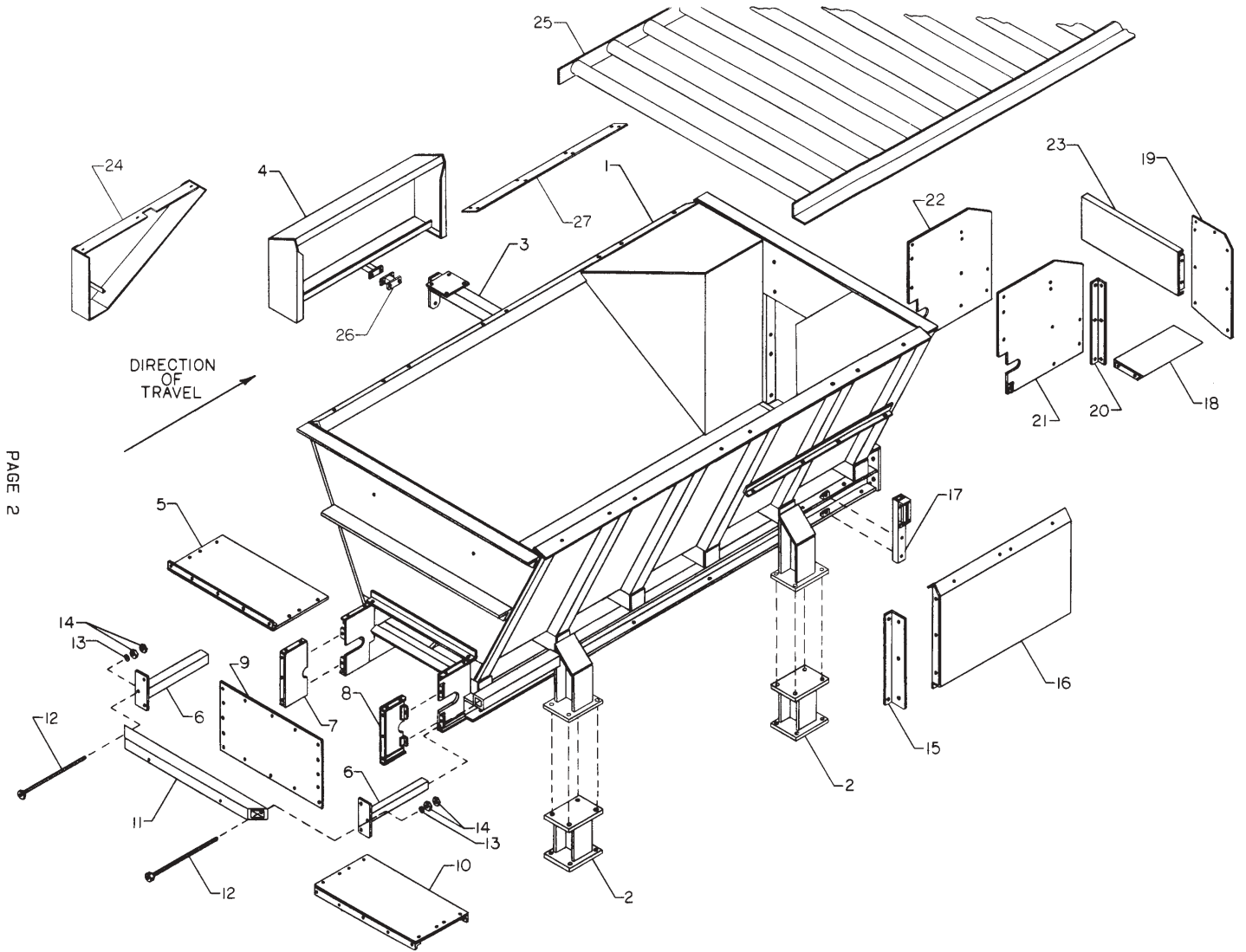

1. PANELS & SHIELDS SECTION

NO.	PART NO.	KEYWORD	DESCRIPTION	NO.	REQ'D
1	90369	FRAME	859DX14 FEEDER MAIN	1	
2	90992	EXTENSION	1-1/2 FT LEG (OFFSET)	OPT	
--	90993	EXTENSION	2-1/2 FT LEG (OFFSET)	OPT	
--	90994	EXTENSION	3 FT LEG (OFFSET)	OPT	
--	90995	EXTENSION	3-1/2 FT LEG (OFFSET)	OPT	
--	90996	EXTENSION	4 FT LEG (OFFSET)	OPT	
3	90364	MOUNT	MOTOR	OPT	
4	121732	SHIELD	MOTOR & GEARBOX	OPT	
5	90357	PANEL	IDLER TOP	1	
6	60608	ADJUSTER	IDLER(ROTOR TYPE)	2	
7	90361	PANEL	IDLER SIDE; LEFT REAR	1	
8	90362	PANEL	IDLER SIDE; RIGHT REAR	1	
9	121727	PANEL	IDLER END	1	
10	90358	PANEL	IDLER BOTTOM	1	
11	90339	BRACKET	IDLER ADJUSTING	1	
12	60430	ROD	IDLER ADJUSTING	2	
13	G131016	WASHER	5/8 FLAT	A/R	
14	G124589	NUT	5/8-11 USS	A/R	
15	121725	SHIELD	CHAIN DRIVE; REAR	1	
16	121733	SHIELD	CHAIN DRIVE	1	
17	90365	BRACKET	CHAIN IDLER	1	
18	121734	SHIELD	CHAIN DRIVE ATTACHING	1	
19	121726	SHIELD	CHAIN DRIVE; FRONT	1	
20	90340	MOUNT	SHIELD	1	
21	90368	PANEL	DISCHARGE SIDE;RIGHT	1	
22	90367	PANEL	DISCHARGE SIDE;LEFT	1	
23	90366	PANEL	DISCHARGE FRONT	1	
24	122207	SHIELD	LT LOWER MOTOR (USE W/3HP 1P MOTOR ONLY)	OPT	
--	122206	SHIELD	RT LOWER MOTOR (USE W/3HP 1P MOTOR ONLY)	OPT	
25	90881	SCREEN	COARSE INFEEED	OPT	
26	90950	SPACER	SHIELD MOUNTING	1	
27	122320	PLATE	SHIELD EXTENSION	1	

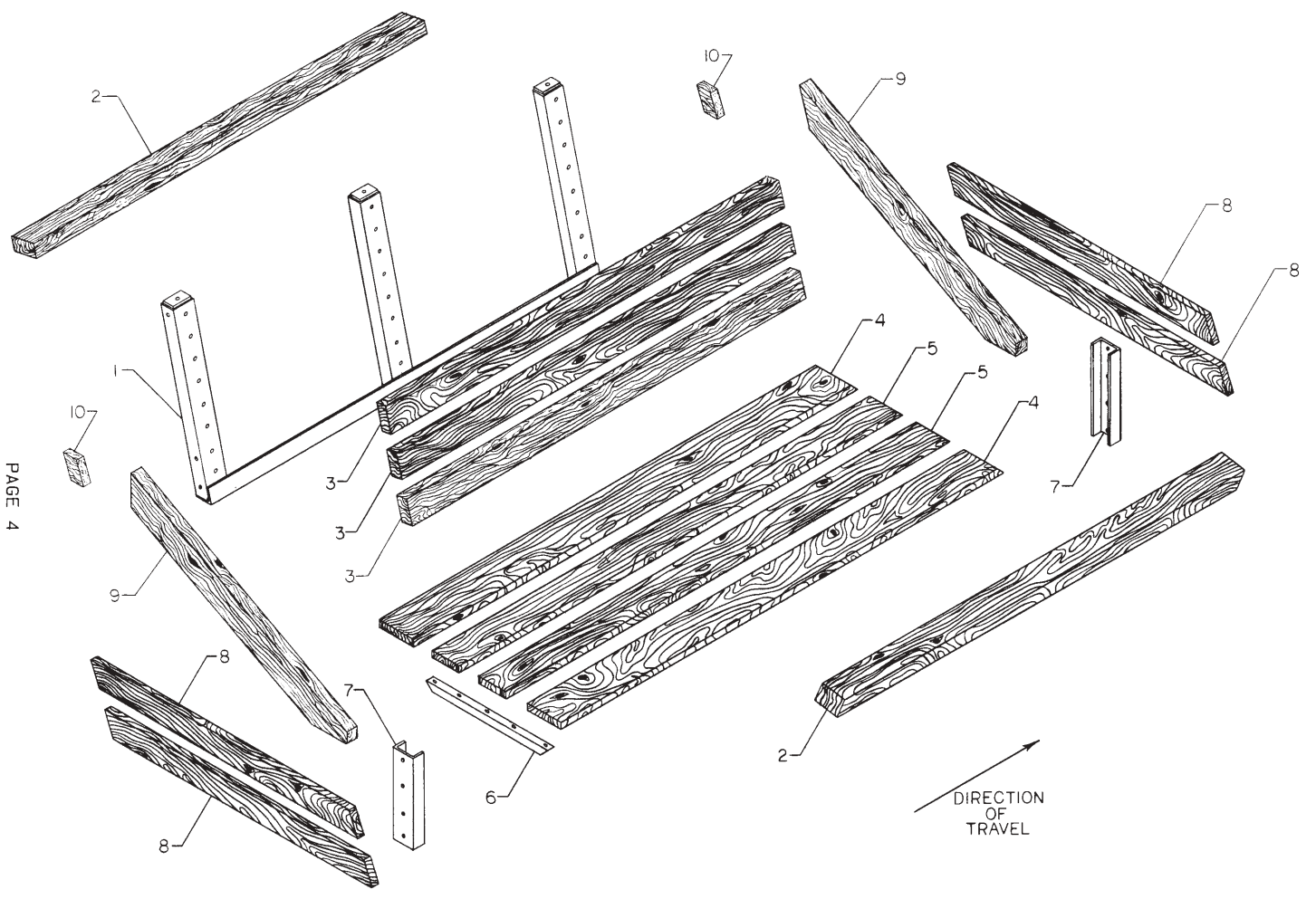

2. BOARDS SECTION

NO.	PART NO.	KEYWORD	DESCRIPTION	NO.	REQ'D
1	90511	FRAME	BATTERBOARD (8 BOARD)	1	
2	13370	BOARD	BUMPER	2	
3	13350	LUMBER	2X6X14FT ROUGH CUT TREATED PINE	8	
4	13353	BOARD	10"X15FT BOTTOM SUPPORT	2	
5	13352	BOARD	8"X15FT BOTTOM SUPPORT	2	
6	90343	ANGLE	BOARD MOUNT	8	
7	90341	MOUNT	END BOARD	2	
8	13354	BOARD	END	4	
9	13372	BRACE	BATTERBOARD TRUSS	2	
10	13426	SPACER	BATTERBOARD END	2	

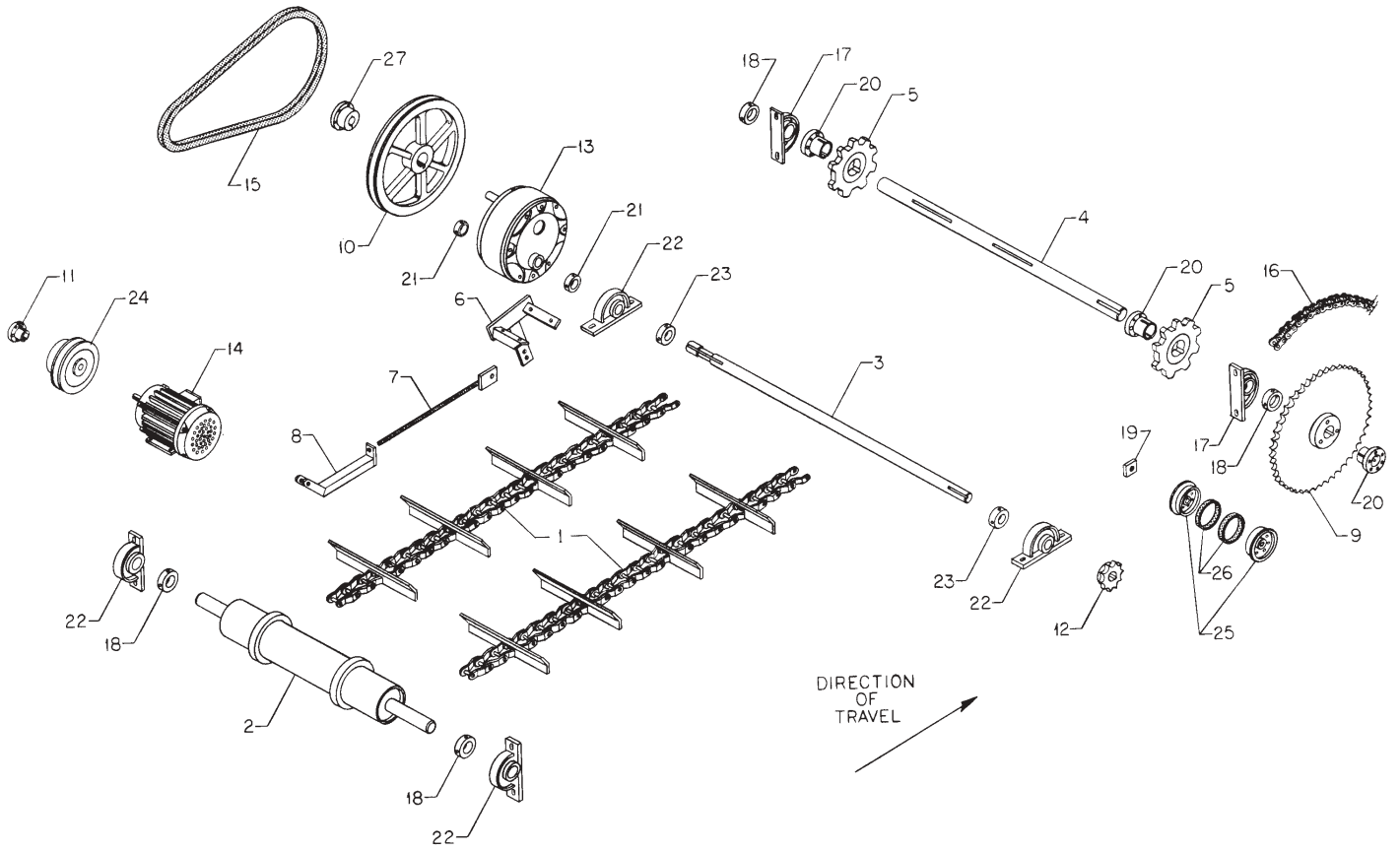

3. DRIVE SECTION

NO.	PART NO.	KEYWORD	DESCRIPTION	NO. REQ'D
1	4533	CHAIN	FEEDER FLIGHT	6
2	10351	IDLER	INFEED FLIGHT CHAIN	1
3	10263	SHAFT	GEARBOX DRIVE	1
4	10352	SHAFT	FRONT DRIVE	1
5	5487	SPROCKET	FEEDER DRIVE	2
6	60431	BRACKET	GEARBOX TENSIONER	1
7	60433	ROD	GEARBOX TENSIONER	1
8	6939	TIGHTENER	IDLER SPRING	1
9	80Q60	SPROCKET	80Q60	1
10	5732	SHEAVE	1B10.8-OD W/1-3/8 BORE	1
--	5052	SHEAVE	1B20.0 PD QD-SK.....INVERTER DRIVE	1
11	5075	BUSHING	QD-SDS 1-1/8.....INVERTER DRIVE	1
12	5721	SPROCKET	80B12 F 1-15/16 BORE	1
13	11134	GEARBOX	24:1,4HP,SHAFT MT 1-15/16	1
14	15162	MOTOR	3H/3P/460/1800/1B2T/TEFC	1
--	15451	MOTOR	3H/1P/230/1800/1B4T/TEFC	OPT
15	B78	BELT	1
--	B99	BELTINVERTER DRIVE	1
16	4365-82	CHAIN	NO.80, 81 PITCHES+CONN.	1
--	4365	CHAIN	NO.80 ROLLER;12 LINKS/FT	A/R
--	4365B	LINK	NO. 80 CONNECTING	A/R
17	3124	BEARING	2-7/16 PILLOW BLOCK	4
--	3126	INSERT	2-7/16 REPLACEMENT BEARING	4
18	3125	COLLAR	2-7/16 ECCENTRIC LOCKING	4
19	2020	NUT	IDLER ADJUSTING	1
20	5663	BUSHING	Q1 2-7/16	3
21	3134	COLLAR	1-15/16 BOSTON LOCKING	2
22	3119	BEARING	1-15/16 PILLOW BLOCK W/COLLAR	2
--	3089	INSERT	1-15/16 REPLACEMENT BEARING	A/R
23	3090	COLLAR	1-15/16 ECCENTRIC LOCKING	A/R
24	5057	SHEAVE	1B6.0PDQDSDS,1A5.6PDQDSDS	1
--	51072	SHEAVE	1B46SDS.....INVERTER DRIVE	1
25	5218	IDLER	4" BELT, 1 OPEN SIDE	2
26	5204	TIRE	CHAIN IDLER	2
27	5961	BUSHING	QD-SK 1-3/8.....INVERTER DRIVE	1

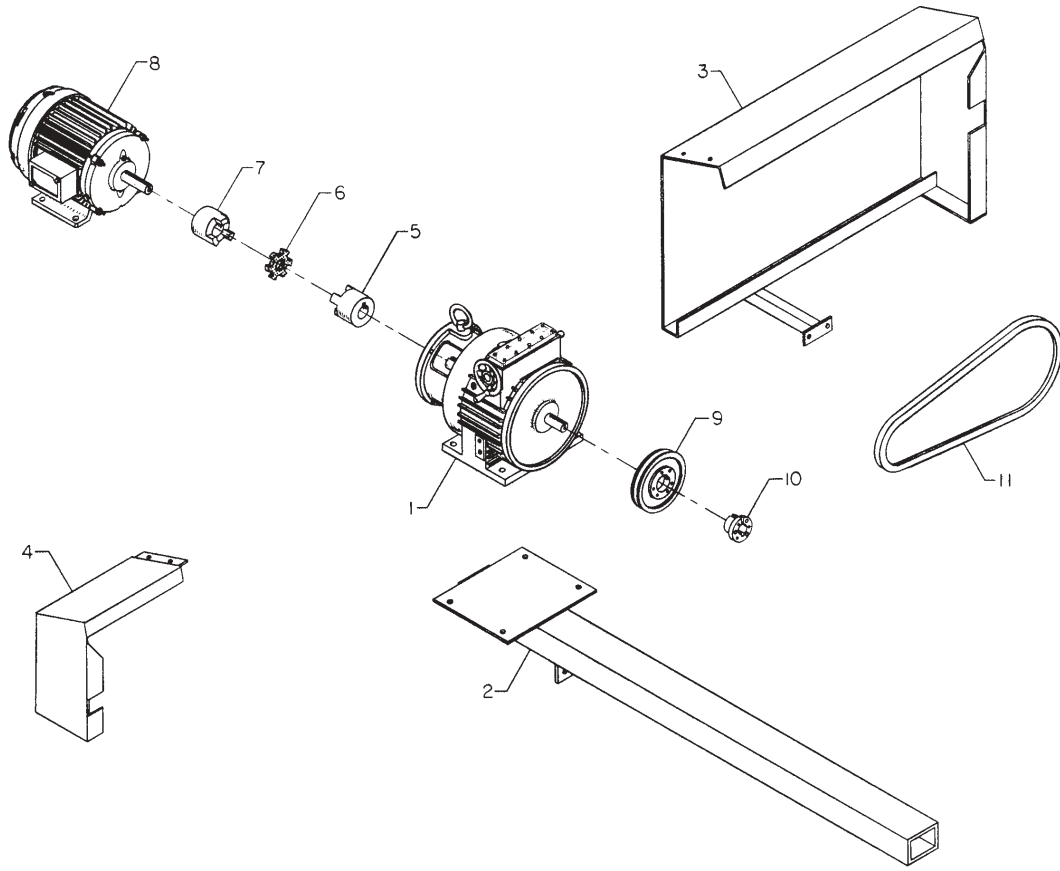

4. VARIABLE SPEED GEARBOX DRIVE - OPTIONAL

NO.	PART NO.	KEYWORD	DESCRIPTION	NO.	REQ'D
1	11190	GEARBOX	3/5HP 1750RPM VAR SPD	1	
2	91004	MOUNT	VARIABLE SPEED GEARBOX	1	
3	122336	SHIELD	MOTOR & GEARBOX/VARIABLE SPEED; LEFT ...	A/R	
--	122389	SHIELD	MOTOR & GEARBOX/VARIABLE SPEED; RIGHT ..	A/R	
4	122337	SHIELD	VARIABLE SPEED GEARBOX; LEFT	A/R	
--	122388	SHIELD	VARIABLE SPEED GEARBOX; RIGHT	A/R	
5	11190B	BODY	FLEX COUPLING 1"	1	
6	11190A	SPIDER	FLEX COUPLING BUNA-N L100	1	
7	11190C	BODY	FLEX COUPLING 1-1/8"	1	
8	15162	MOTOR	3H/3P/460/1800/182T/TEFC	1	
9	5057	SHEAVE	1B6.0PDQSDS, 1A5.6PDQSDS	1	
10	5075	BUSHING	QD-SDS 1-1/8	1	
11	B85	BELT	1	

NOTE: SOME ITEMS IN THIS KIT WILL
 REPLACE SIMILAR STANDARD ITEMS
 PREVIOUSLY DOCUMENTED.

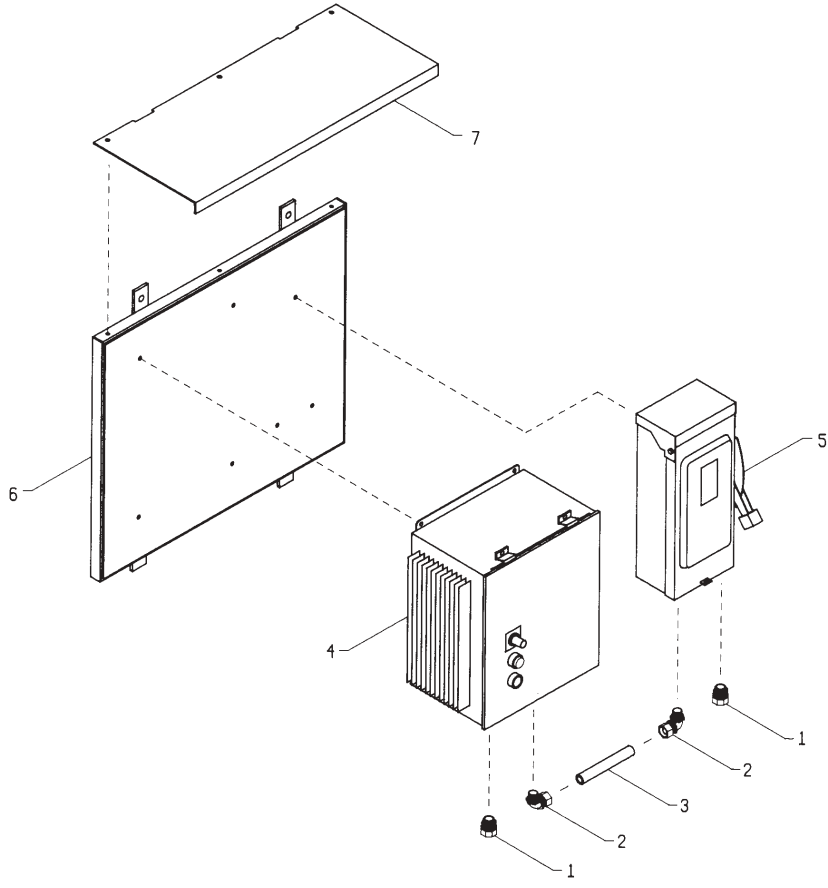

5. INVERTER DRIVE SECTION -- OPTIONAL

NO.	PART NO.	KEYWORD	DESCRIPTION	NO. REQ'D
1	15094	CONNECTOR	3/8 STRAIGHT LIQUID TIGHT	2
2	15096	CONNECTOR	3/8 90 DEG. LIQUID TIGHT	2
3	15089	CONDUIT	3/8 LIQUATITE, 5-1/2 LONG	1
4	15765	INVERTER	V14030C NEMA4 ENCLOSURE	1
5	15104	SWITCH	SAFETY 30 AMP 3PHASE	1
6	91622	PANEL	INVERTER/SWITCH	1
7	122962	HOOD	INVERTER/SWITCH	1

NOTE: SEE DRIVE SECTION FOR SHEAVES, ETC.

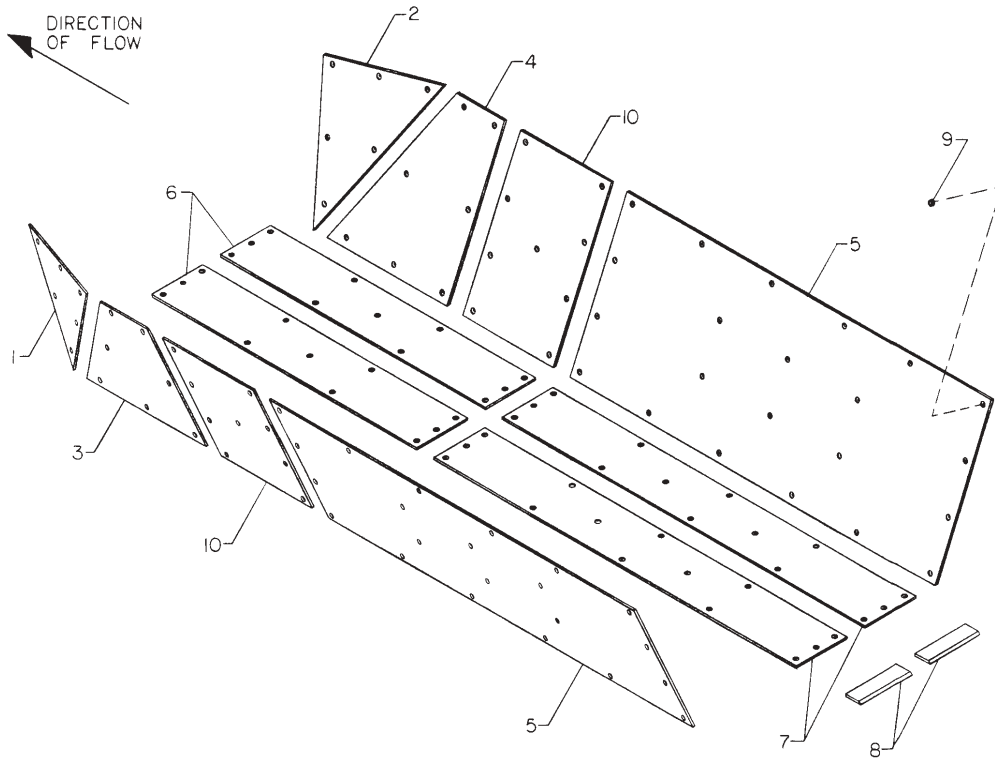

6. POLYETHYLENE SLIDE KIT - OPTIONAL

NO.	PART NO.	KEYWORD	DESCRIPTION	NO.	REQ'D
1	13405	SLIDE	LEFT PARTITION	1	
2	13406	SLIDE	RIGHT PARTITION	1	
3	13407	SLIDE	LEFT SHORT WALL	1	
4	13408	SLIDE	RIGHT SHORT WALL	1	
5	13409	SLIDE	MAIN LONG WALL	2	
6	13419	SLIDE	5'10" TROUGH	2	
7	13424	SLIDE	8' TROUGH	2	
8	91006	FLAT	TOP SLIDE	2	
9	1573	WASHER	WELD 1.3/8 X 3/8 X 14 GA	138	
10	13422	SLIDE	2' WALL	2	



← 1

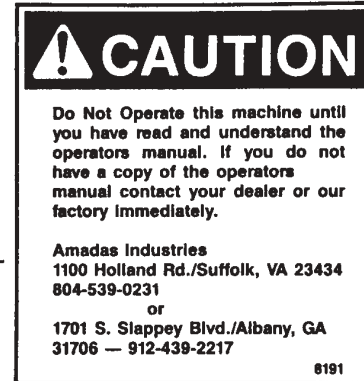

2 →



← 3

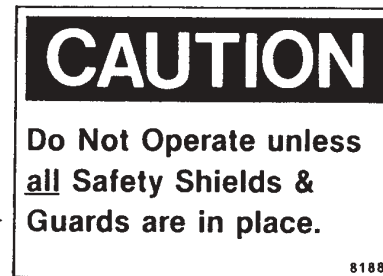

4 →

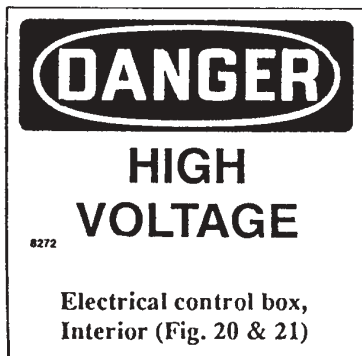

← 5

7. DECALS SECTION

NO.	PART NO.	KEYWORD	DESCRIPTION	NO.	REQ'D
1	8180	DECAL	DANGER: REMOTE OPERATION	2	
2	8191	DECAL	WARNING: READ OP. MANUAL	1	
3	8190	DECAL	CAUTION: (LIST)	1	
4	8188	DECAL	CAUTION: SHIELDS	2	
5	8272	DECAL	DANGER: HIGH VOLTAGE.....INVERTER DRIVE	1	

NOTE: THE FOLLOWING DECALS ARE USED BUT
ARE NOT SHOWN.

--	8343	DECAL	AMADAS "AMERICAN MADE"	1	
--	80030	DECAL	"AMADAS"; 10"	2	
--	8398	DECAL	"AMADAS"; 36" GRAY	1	

REFER TO OPERATOR'S MANUAL FOR LOCATION
OF DECALS & ADDITIONAL SAFETY
INFORMATION

NUMERICAL PARTS INDEX

PART NO.	PAGE	PART NO.	PAGE	PART NO.	PAGE
878	7	3126	7		
885	9	3134	7		
899	7	4365	7		
G124589	3	4365-B2	7		
G131016	3	4365B	7		
10263	7	4533	7		
10351	7	5052	7		
10352	7	5057	7,09		
11134	7	5075	7,09		
11190	9	51072	7		
11190A	9	5204	7		
11190B	9	5218	7		
11190C	9	5663	7		
121725	3	5687	7		
121726	3	5721	7		
121727	3	5732	7		
121732	3	5961	7		
121733	3	60430	3		
121734	3	60431	7		
122206	3	60433	7		
122207	3	60608	3		
122320	3	6939	7		
122336	9	80060	7		
122337	9	80030	15		
122388	9	8180	15		
122389	9	8188	15		
122962	11	8190	15		
13350	5	8191	15		
13352	5	8272	15		
13353	5	8343	15		
13354	5	8398	15		
13370	5	90339	3		
13372	5	90340	3		
13405	13	90341	5		
13406	13	90343	5		
13407	13	90357	3		
13408	13	90358	3		
13409	13	90361	3		
13419	13	90362	3		
13422	13	90364	3		
13424	13	90365	3		
13426	5	90366	3		
15089	11	90367	3		
15094	11	90368	3		
15096	11	90369	3		
15104	11	90511	5		
15162	7,09	90881	3		
15451	7	90950	3		
1573	13	90992	3		
15765	11	90993	3		
2020	7	90994	3		
3089	7	90995	3		
3090	7	90996	3		
3119	7	91004	9		
3124	7	91006	13		
3125	7	91622	11		

WARRANTY

For AMADAS INDUSTRIES Industrial Machinery

A. General Provisions

AMADAS INDUSTRIES ("Company") warrants that each machine manufactured by it and sold under its trademark shall be free from defects in material and workmanship. The company's sole obligation under this warranty shall be limited to making good, F.O.B. Company factory, any part of its product which under normal and proper use and maintenance proves defective in material and workmanship within six months after delivery to the Buyer provided that notice of such defect and satisfactory proof thereof is promptly given by the Buyer to the Company, with transportation charges prepaid, and Company's examination proves such part to have been defective.

This warranty does not apply in respect to damage to any product or accessory or attachment thereof caused by overloading or other misuse, neglect or accident nor does this warranty apply to any product, or accessory or attachment thereof which shall have been repaired or altered by other than the Company which, in the sole judgement of the Company affects the performance, stability or purpose for which it was manufactured.

With respect to tires, engines, or other trade accessories, the Company makes no warranty whatsoever and the buyer shall rely solely upon the existing warranties, if any, of the respective manufacturers thereof.

B. Unapproved Service or Modification

All obligations of AMADAS INDUSTRIES under this warranty are terminated if the machinery is modified or altered in ways not approved by AMADAS INDUSTRIES

C. Owner's Responsibilities

- a. Read the operator's manual before operating the machinery.
- b. Perform all necessary maintenance as described in the operators's manual.
- c. Contact AMADAS INDUSTRIES promptly on any warranty claim.
- d. Sign the AMADAS INDUSTRIES machine delivery form and return promptly as this validates the warranty.